

Power Box Max

Product specification



1. Product overview

Power Box Max is a Dashcam video extension power box that supports the expansion of 4 AHD inputs or 3 AHD inputs plus 1 IPC input. It has AI extension capability and supports left, right, and rear Blind Spot Detection (BSD) audio-visual alarms. It also supports quick power supply from the original vehicle's OBD port and OBD data parsing capability. It is commonly used in Dashcam products that require vehicle blind spot compensation and cargo monitoring in the scenes of medium and large freight vehicles.

2. Product features

- Support 3-way IO detection and 1-way iButton access.
- Support 1-way IO output with a current of up to 0.5A.
- Support 3-way RS232, where RS232-1 is default for R-Watch, RS232-2 is for B3 left, and RS232-3 is for B3 right.
- Powered by OBD, with 2 built-in CAN channels, support for J1939 protocol, and a choice between J1708/J1850/K-LINE protocols.
- Support 4-way AHD input or 3-way AHD plus 1-way IPC input.
- Support 1-way video output, configurable as AHD or CVBS output.
- Equipped with AI detection capability, supporting up to 3-way BSD with time division and real-time operation of 2-way BSD, and support for 2-way B3 blind spot indicators.

3. 3Product Specifications

Product number	
	Power Box Max
Interface	
RS232	3 ch, 232-1 connects to R-Watch by default, 232-2 connects to the left side of B3, and 232-3 connects to the right side of B3
SENSOR IN	3 inputs
SENSOR OUT	1 output
iButton	1 channel
CAN	2 ch
K-LINE	1ch (和 J1708/J1850/K-LINE) choose one of three
USB	1 x USB2.0 (Type A) , Used for local upgrade
LAN	1 ch, Connect to AD Plus 2.0
Video	
Enter	4 channels AHD or 3 channels AHD+1 channel IPC
Output	1 ch video output, configurable as AHD or CVBS output.
Total Resource	3 channels 720P 15 frames + 1 channels 720P 10 frames It can support up to 3 channels of BSD for time-sharing and 2 channels of BSD for real-time operation
Power Related	
Power supply	12V and 24V vehicles (self-adaptive)
Standby power consumption	<ul style="list-style-type: none">● In standby mode: 13.5V@4.2mA, 27V@2.3mA● In sleep mode (4G and MCU powered): 13.5V@59.8mA, 27V@41.8mA

	<ul style="list-style-type: none"> ● Typical power consumption (with AD Plus2.0 and 4 cameras in Power Box Max): about 25W ● Full-load power consumption (with dual SD cards installed, SIM card for dialing, Wi-Fi turned on, additional 4 cameras, and infrared lamp turned on): about 30W <p>* The above data are test data obtained in a specific environment in the laboratory, and may vary with the individual product differences, service environment, and testing methods.</p>
Physical properties	
Size (mm)	192mm x 98.5mm x 30mm
Weight (g)	554g (Bare Metal)
Working environment	
Operating temperature	-40°C~+70°C (-40° F ~ +158° F)
Storage temperature	-40°C~+85°C (-40° F ~ +185° F)
Working humidity	15%-95% (No condensation)
LED Indicator Status	
Power Status Lights	Off/Green Off: The device is not powered on Steady green: The device is powered normally
Network Status Indicator	Off/Red Off: Means the connection between AD Plus and Power Box Max is failed Red: Means the connection between AD Plus and Power Box Max is connected

4. Dimensions (mm)

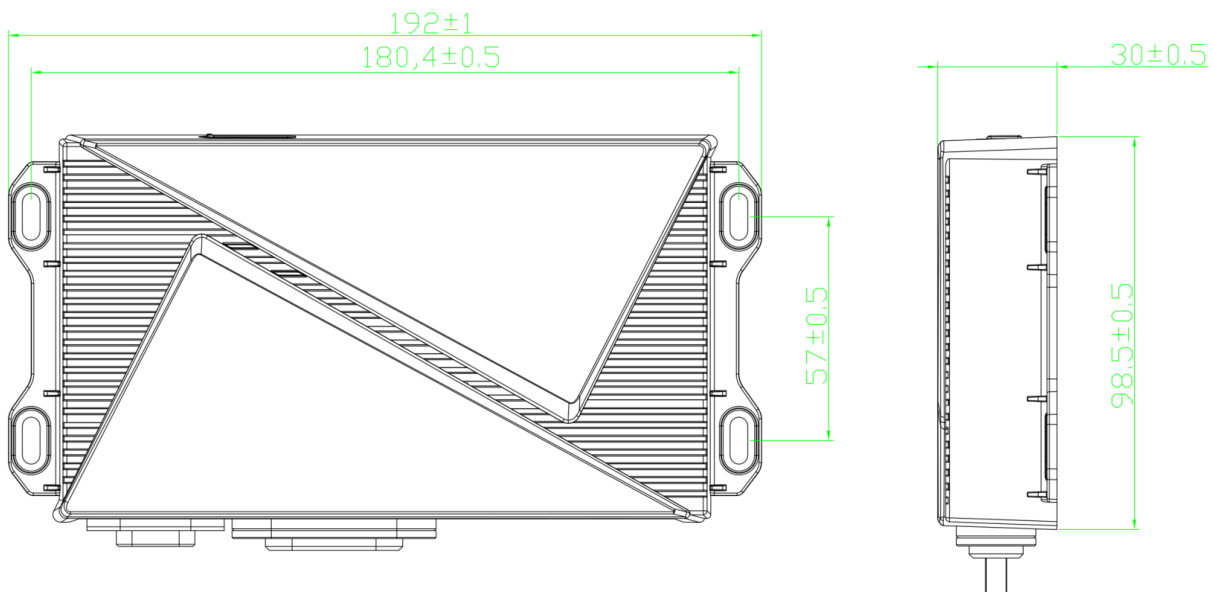

5. Panel interface

Front panel:



Number	Silk screen/Icon	Explanation
1		USB2.0 (Type A), Used for local upgrade

Rear panel:

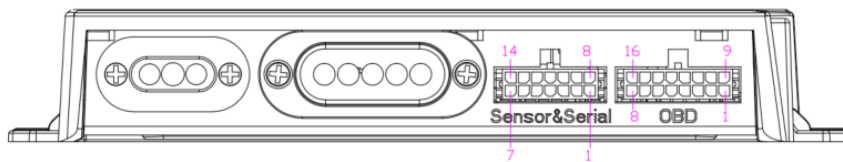

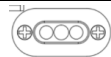
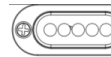
Number	Silk screen/Icon	Explanation
1	Sensor & Serial	External expansion I/O, I-Button and serial.
2	OBD	Connect the vehicle OBD interface
3		Connect to AD Plus 2.0 and video output
4		Video input and IPC input

6. Definition of external cable interface

(1) Sensor & Serial, External expansion I/O, I-Button and serial.

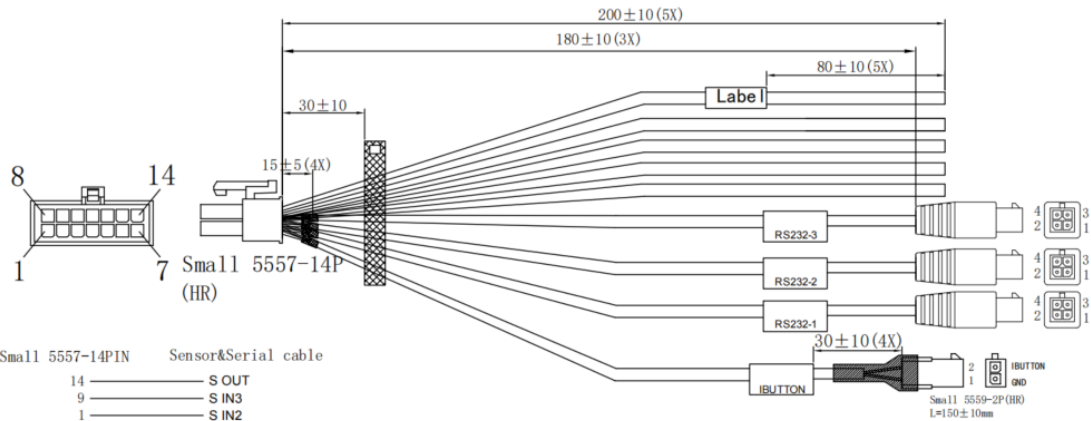

Small 5557-14PIN Sensor&Serial cable

14	S OUT
9	S IN3
1	S IN2
8	S IN1
7	GND

Small 5557-14PIN Small 5559-4P(-1)

7	4	GND	Black
232TX-1	4	232TX-1	Yellow
232RX-1	11	232RX-1	White
10	1	+12V	Red

Small 5557-14PIN Small 5559-4P(-2)

7	4	GND	Black
232TX-2	5	232TX-2	Yellow
232RX-2	12	232RX-2	White
10	1	+12V	Red

Small 5557-14PIN Small 5559-4P(-3)

7	4	GND	Black
232TX-3	6	232TX-3	Yellow
232RX-3	13	232RX-3	White
10	1	+12V	Red

Small 5557-14PIN Small 5559-2P

3	1	GND	Black
2	2	IBUTTON	Red

(2) OBD cable interface definition (standard OBD-II(16PIN), optional 9PIN round head)

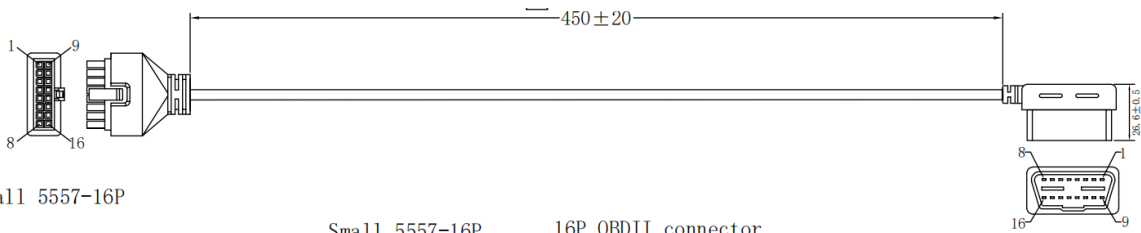

Small 5557-16P

Small 5557-16P 16P OBDII connector

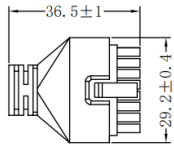

J1850 Bus+	1	Orange	2
CAN1-H	2	Yellow	3
CAN0-H	3	Blue	6
L-LINE	4	Green	15
J1708 Bus-	5	Brown	12
GND	7+8	Black	4 24AWG ⚠
J1850 Bus-	9	Orange-White	10
CAN1-L	10	White	11
CAN0-L	11	Blue-White	14
J1708 Bus+	12	Brown-White	13
K-LINE	13	Green-White	7
12/24V	15	Red	16 24AWG
GND	16	Black	5 24AWG

Optional 9PIN wire

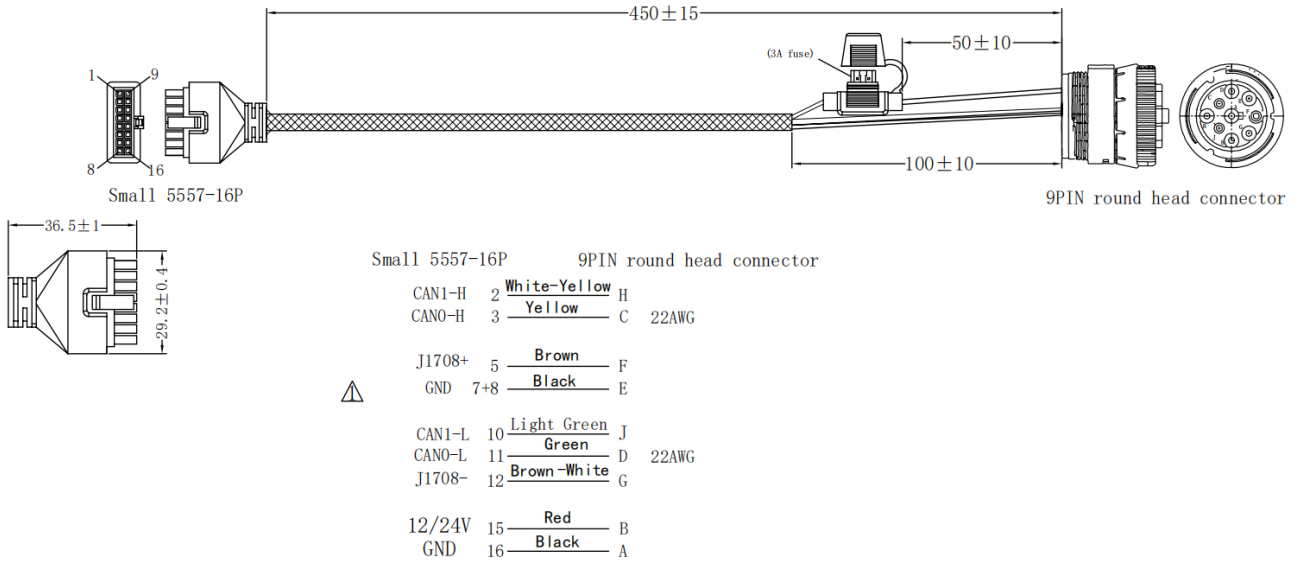

Optional wire

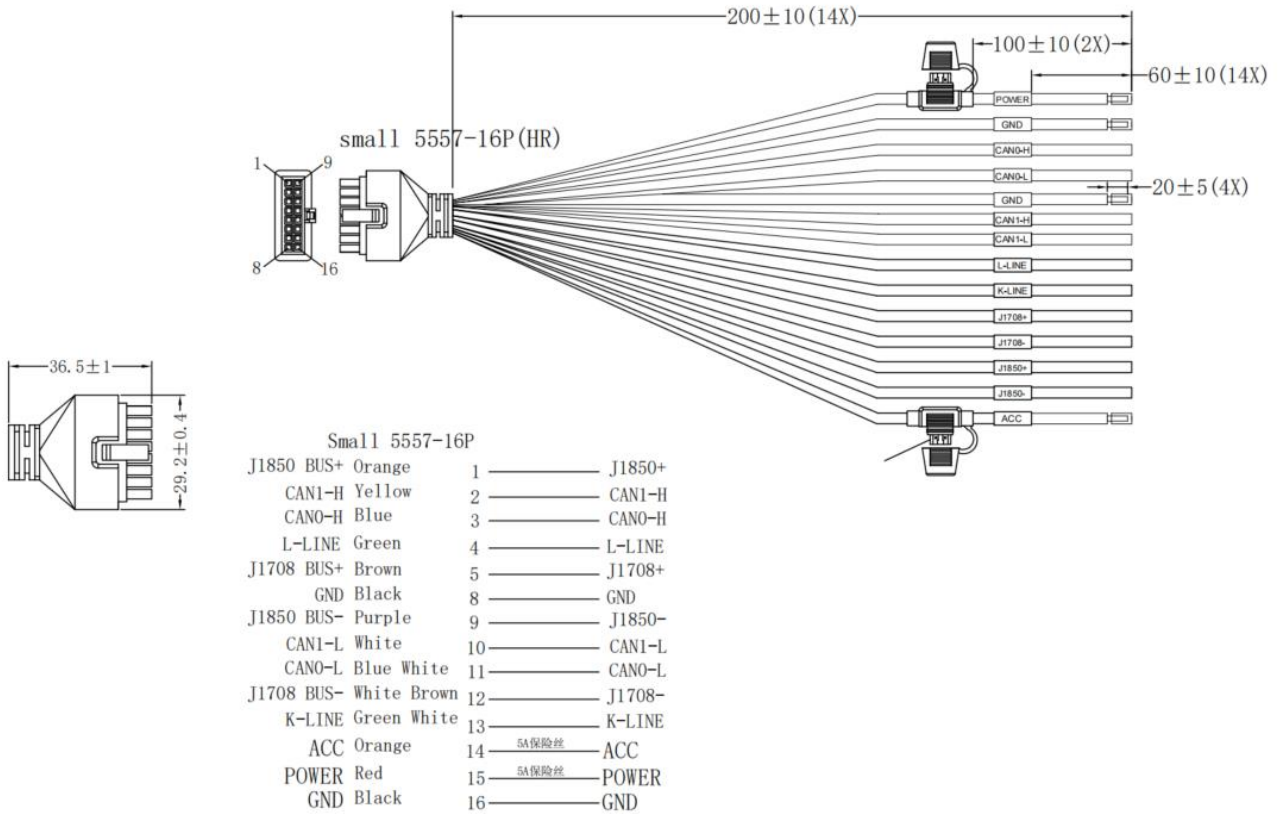

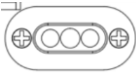
(3)  Host connecting cable (AD Plus 2.0) and Video output.

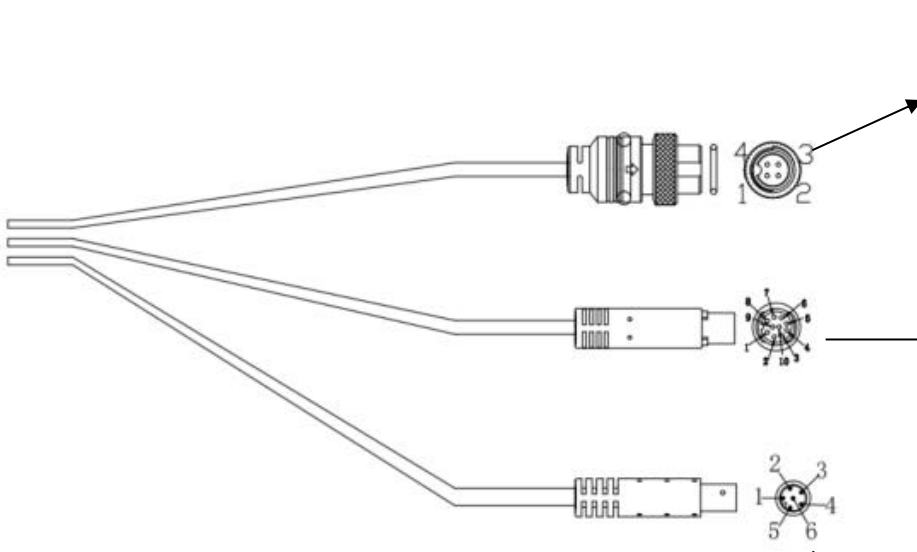

Interface definition
RS765-4 female (AVDOUT)

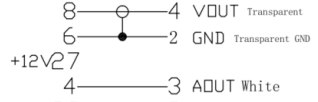

Interface definition
10PIN male connector

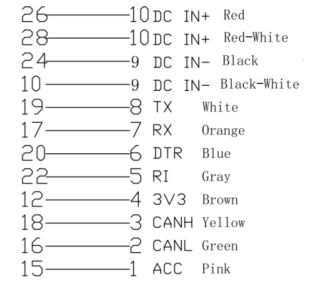

Interface definition
6P male connector(LAN)

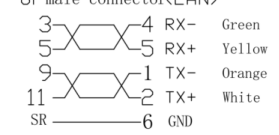

(4)  Video input and IPC input.

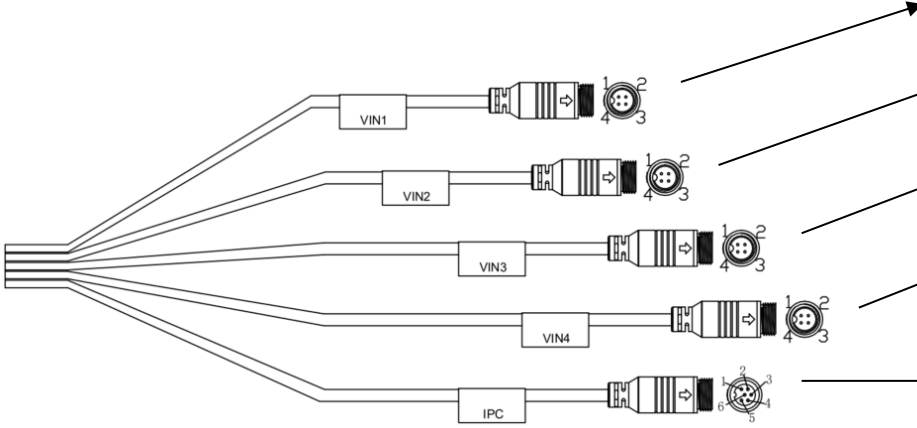

Interface definition
RS765-4 male(VIN1)

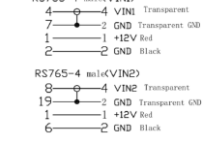

Interface definition
RS765-4 male(VIN2)

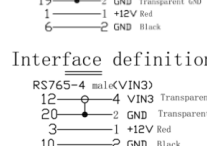

Interface definition
RS765-4 male(VIN3)

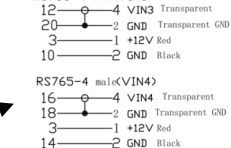

Interface definition
RS765-4 male(VIN4)



Interface definition
RS765-6 male (IPC)

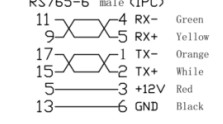

7. System connection diagram (Connecting AD Plus 2.0)

